

GUÍA DE ACTIVIDADES

PRIMERO LEE

a los niños

NT1



Tomo 1

¡RECORDEMOS EL ALFABETO!

<table border="1"> <tr><td>A</td><td>a</td></tr> <tr><td>A</td><td>a</td></tr> </table> 	A	a	A	a	<table border="1"> <tr><td>B</td><td>b</td></tr> <tr><td>B</td><td>b</td></tr> </table> 	B	b	B	b	<table border="1"> <tr><td>C</td><td>c</td></tr> <tr><td>C</td><td>c</td></tr> </table> 	C	c	C	c	<table border="1"> <tr><td>Ch</td><td>ch</td></tr> <tr><td>Ch</td><td>ch</td></tr> </table> 	Ch	ch	Ch	ch	<table border="1"> <tr><td>D</td><td>d</td></tr> <tr><td>D</td><td>d</td></tr> </table> 	D	d	D	d
A	a																							
A	a																							
B	b																							
B	b																							
C	c																							
C	c																							
Ch	ch																							
Ch	ch																							
D	d																							
D	d																							
<table border="1"> <tr><td>E</td><td>e</td></tr> <tr><td>E</td><td>e</td></tr> </table> 	E	e	E	e	<table border="1"> <tr><td>F</td><td>f</td></tr> <tr><td>F</td><td>f</td></tr> </table> 	F	f	F	f	<table border="1"> <tr><td>G</td><td>g</td></tr> <tr><td>G</td><td>g</td></tr> </table> 	G	g	G	g	<table border="1"> <tr><td>H</td><td>h</td></tr> <tr><td>H</td><td>h</td></tr> </table> 	H	h	H	h	<table border="1"> <tr><td>I</td><td>i</td></tr> <tr><td>I</td><td>i</td></tr> </table> 	I	i	I	i
E	e																							
E	e																							
F	f																							
F	f																							
G	g																							
G	g																							
H	h																							
H	h																							
I	i																							
I	i																							
<table border="1"> <tr><td>J</td><td>j</td></tr> <tr><td>J</td><td>j</td></tr> </table> 	J	j	J	j	<table border="1"> <tr><td>K</td><td>k</td></tr> <tr><td>K</td><td>k</td></tr> </table> 	K	k	K	k	<table border="1"> <tr><td>L</td><td>l</td></tr> <tr><td>L</td><td>l</td></tr> </table> 	L	l	L	l	<table border="1"> <tr><td>Ll</td><td>ll</td></tr> <tr><td>Ll</td><td>ll</td></tr> </table> 	Ll	ll	Ll	ll	<table border="1"> <tr><td>M</td><td>m</td></tr> <tr><td>M</td><td>m</td></tr> </table> 	M	m	M	m
J	j																							
J	j																							
K	k																							
K	k																							
L	l																							
L	l																							
Ll	ll																							
Ll	ll																							
M	m																							
M	m																							
<table border="1"> <tr><td>N</td><td>n</td></tr> <tr><td>N</td><td>n</td></tr> </table> 	N	n	N	n	<table border="1"> <tr><td>Ñ</td><td>ñ</td></tr> <tr><td>Ñ</td><td>ñ</td></tr> </table> 	Ñ	ñ	Ñ	ñ	<table border="1"> <tr><td>O</td><td>o</td></tr> <tr><td>O</td><td>o</td></tr> </table> 	O	o	O	o	<table border="1"> <tr><td>P</td><td>p</td></tr> <tr><td>P</td><td>p</td></tr> </table> 	P	p	P	p	<table border="1"> <tr><td>Q</td><td>q</td></tr> <tr><td>Q</td><td>q</td></tr> </table> 	Q	q	Q	q
N	n																							
N	n																							
Ñ	ñ																							
Ñ	ñ																							
O	o																							
O	o																							
P	p																							
P	p																							
Q	q																							
Q	q																							
<table border="1"> <tr><td>R</td><td>r</td></tr> <tr><td>R</td><td>r</td></tr> </table> 	R	r	R	r	<table border="1"> <tr><td>S</td><td>s</td></tr> <tr><td>S</td><td>s</td></tr> </table> 	S	s	S	s	<table border="1"> <tr><td>T</td><td>t</td></tr> <tr><td>T</td><td>t</td></tr> </table> 	T	t	T	t	<table border="1"> <tr><td>U</td><td>u</td></tr> <tr><td>U</td><td>u</td></tr> </table> 	U	u	U	u	<table border="1"> <tr><td>V</td><td>v</td></tr> <tr><td>V</td><td>v</td></tr> </table> 	V	v	V	v
R	r																							
R	r																							
S	s																							
S	s																							
T	t																							
T	t																							
U	u																							
U	u																							
V	v																							
V	v																							
<table border="1"> <tr><td>W</td><td>w</td></tr> <tr><td>W</td><td>w</td></tr> </table> 	W	w	W	w	<table border="1"> <tr><td>X</td><td>x</td></tr> <tr><td>X</td><td>x</td></tr> </table> 	X	x	X	x	<table border="1"> <tr><td>Y</td><td>y</td></tr> <tr><td>Y</td><td>y</td></tr> </table> 	Y	y	Y	y	<table border="1"> <tr><td>Z</td><td>z</td></tr> <tr><td>Z</td><td>z</td></tr> </table> 	Z	z	Z	z					
W	w																							
W	w																							
X	x																							
X	x																							
Y	y																							
Y	y																							
Z	z																							
Z	z																							

GUÍAS DE TRABAJO

PRIMERO LEE

NT1

Nombre: _____

Curso: _____

Así soy yo

(Dibújate)

© FUNDACIÓN EDUCACIONAL CRECER CON TODOS. 2018. Registro N°258.978. Todos los derechos reservados."

"La presente obra se encuentra protegida por la ley 17.336 de Propiedad Intelectual, incluyendo sus textos, imágenes, gráficos, y cualquier otro elemento contenido en este libro. Fundación Educacional Crecer con Todos se reserva todos los derechos en calidad de titular de la obra, lo que se encuentra acreditado mediante el Registro N°258.976 del Departamento de Derechos Intelectuales de Chile. El uso no autorizado de esta obra, incluyendo – pero no limitado a- su reproducción, adaptación, comunicación pública, distribución o venta se encuentra sancionado en la ley con penas de reclusión o multas de hasta 1.000 unidades tributarias mensuales. La Fundación Educacional Crecer con Todos hace reserva de toda otra acción o derecho que pueda impetrar contra los responsables."

Edición año 2020.





Fundación Crecer con Todos

© Fundación Educacional Crecer con Todos 2015, 2020.

Registro N°258.978

Impreso en Chile

Coordinación general:

Paula Cruzat

Loreto Iglesias

Francisca Labayru

Autoría:

Romina Castro

Francisca Santamaría

Diagramación e ilustraciones:

Patricio Roco

Valentina Iriarte

Carolina Celis

UNIDAD 1

MI ESCUELA



PRIMERO
LEE



Marca con una X las colecciones que hayas explorado.

TABLA PARA REGISTRO DE COLECCIONES		
		
		
		
		
		



UNIDAD 2

SOMOS ÚNICOS Y ÚNICAS

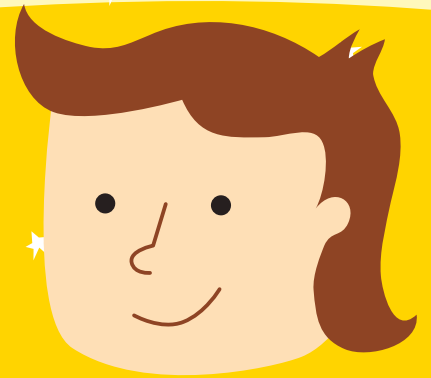

PRIMERO
LEE



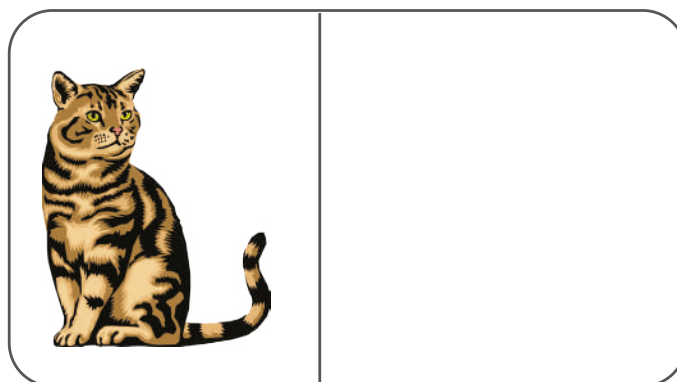
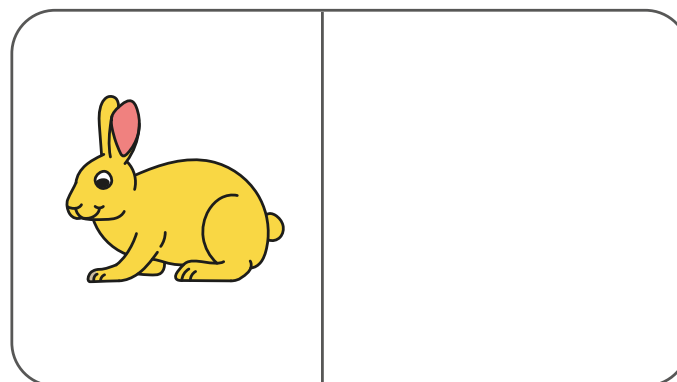
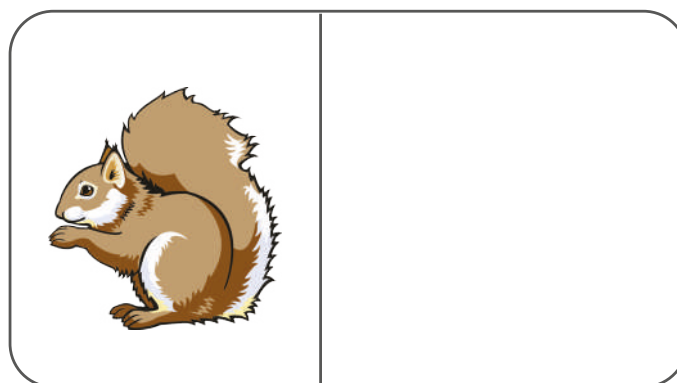
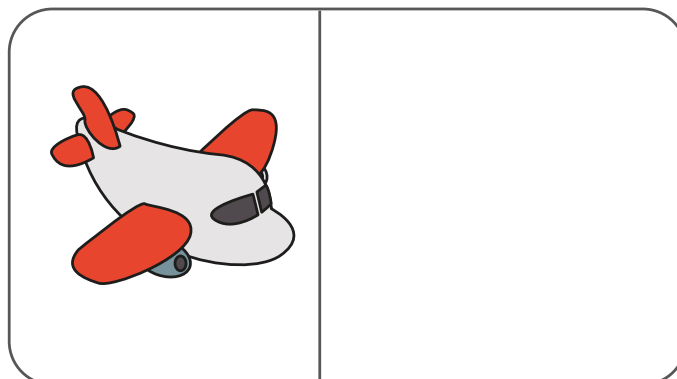

Dibuja un objeto que rime con cada dibujo.







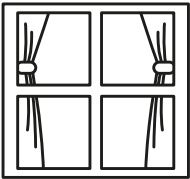
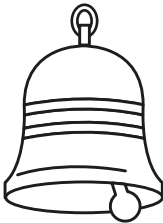

Reconocer rimas

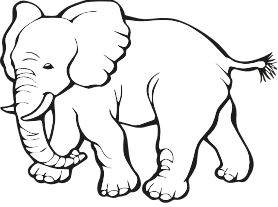
En cada conjunto pinta el o los objetos que rimen con el modelo.

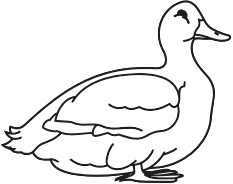
	  
---	--

	  
--	---

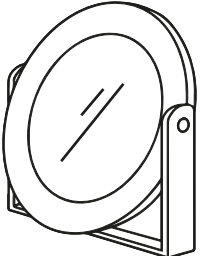
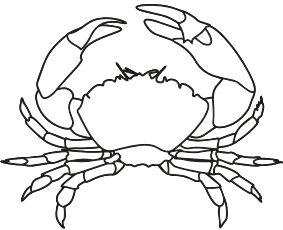
	  
---	--



Reconocer rimas

Encierra en un círculo el elemento que **no rima** con el modelo.

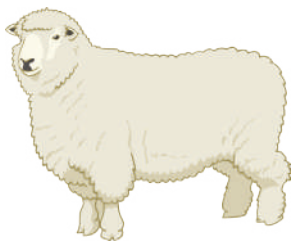
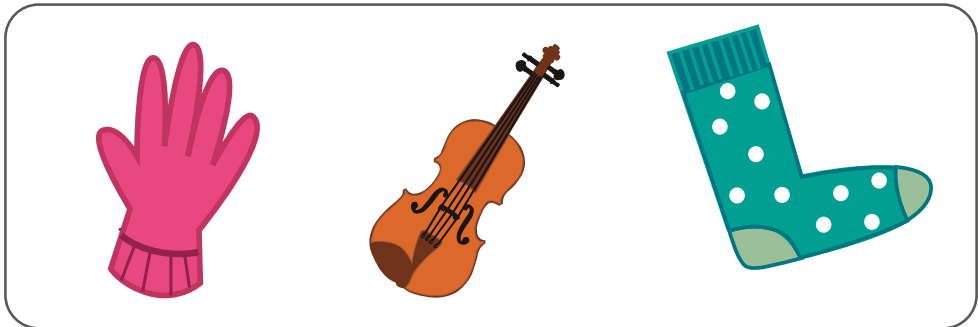
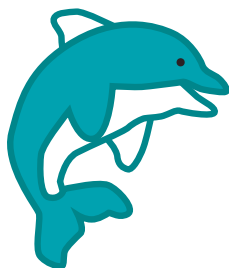
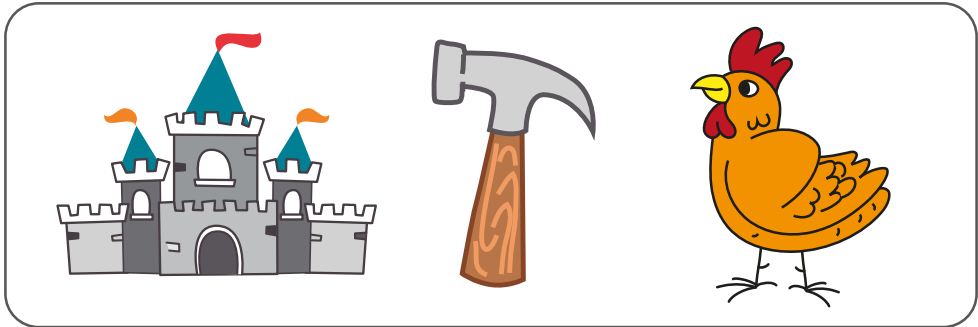



Representar gráficamente distintos trazos

Repasa con el dedo y luego con tu lápiz el camino que debe seguir mamá pata para encontrar a sus patitos.

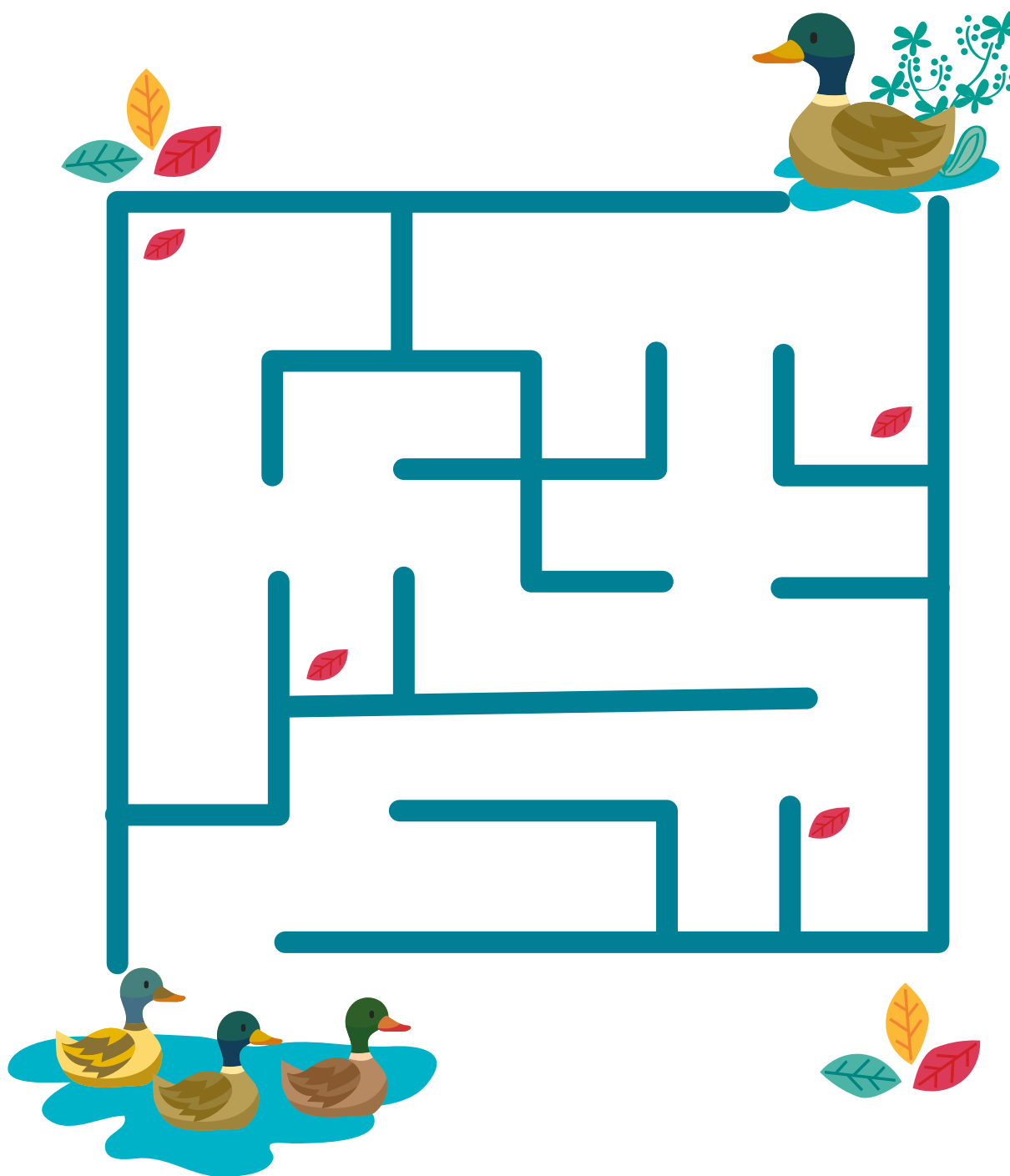



Representar gráficamente distintos trazos

Repasa con el dedo y luego con tu lápiz el camino que debe seguir Pedro para llegar a la pelota.





Identificar rimas

En cada grupo, pinta el dibujo que no rima con los demás.

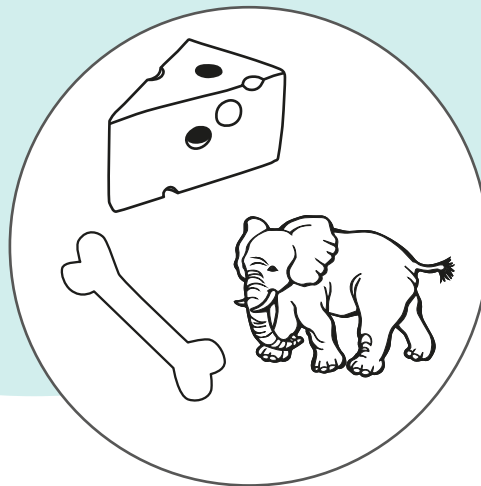
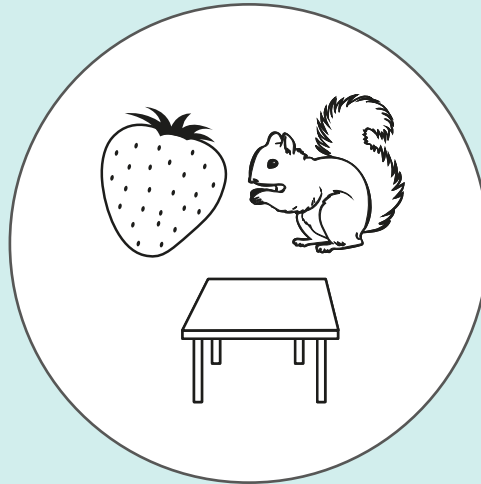
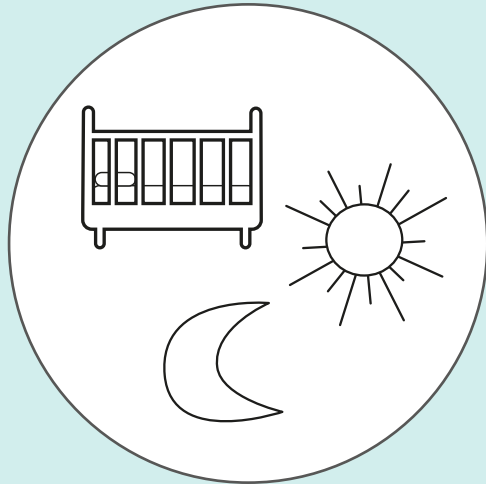
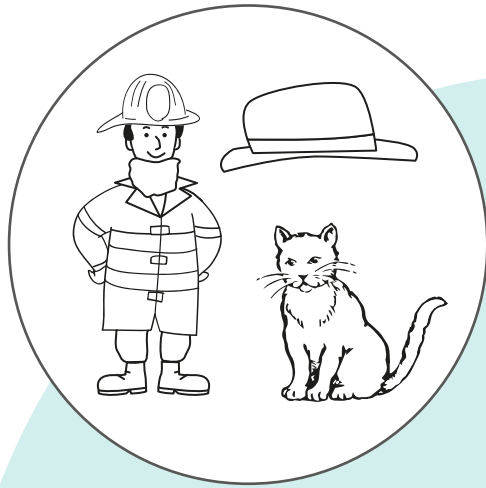



¿De qué tamaño es un ojo, una mano o niños de prekínder en la vida real? Utiliza tu cuerpo o el de tus compañeros para comparar.

Dibuja en el , al lado del modelo, un objeto **más pequeño**.

Dibuja en el , al lado del modelo, un objeto **más grande**.

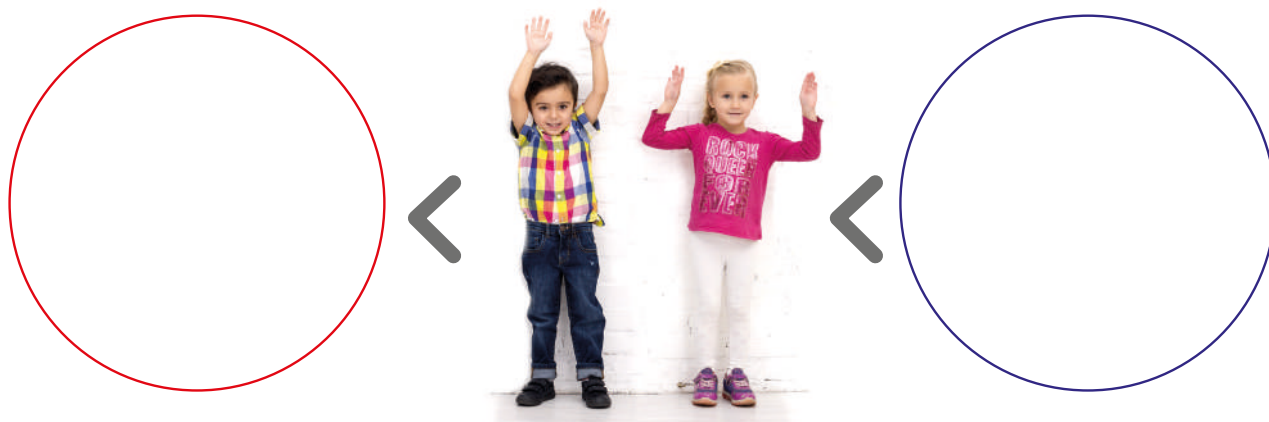
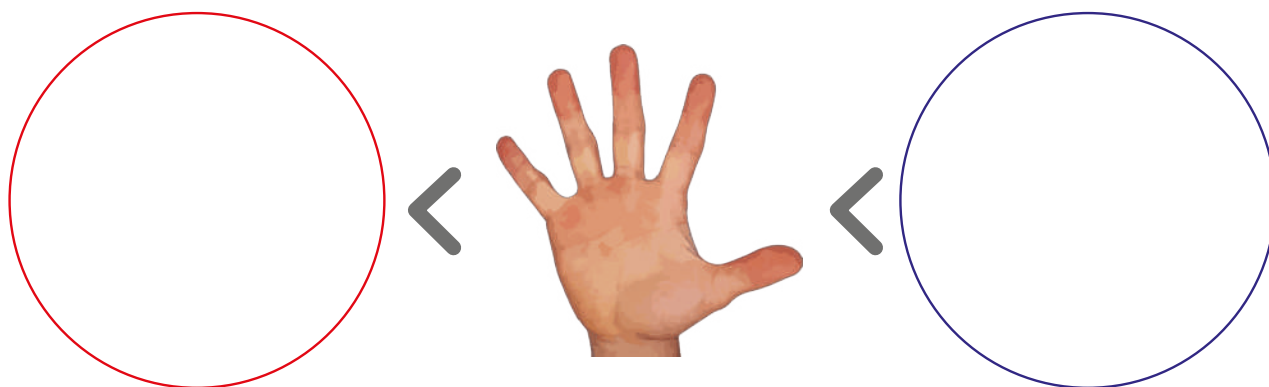



Comparar distintos objetos en función de sus propiedades relativas

9 actividad

Compara tu altura con la de tus compañeros, compañeras, educadoras y/o diferentes objetos de la sala. Dibújate en la silueta que está al centro.

Dibuja en el alguien o algo que sea **más alto o alta que tú.**

Dibuja en el alguien o algo que sea **más bajo que tú.**

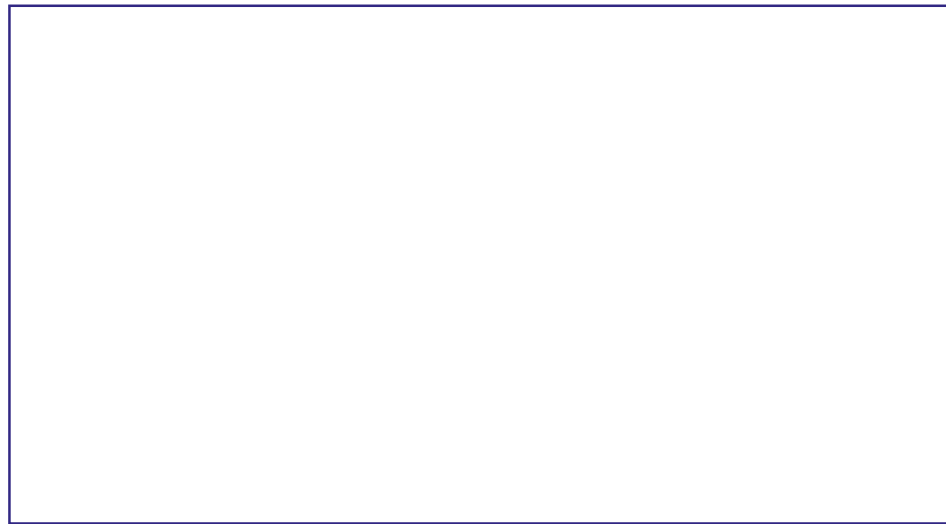
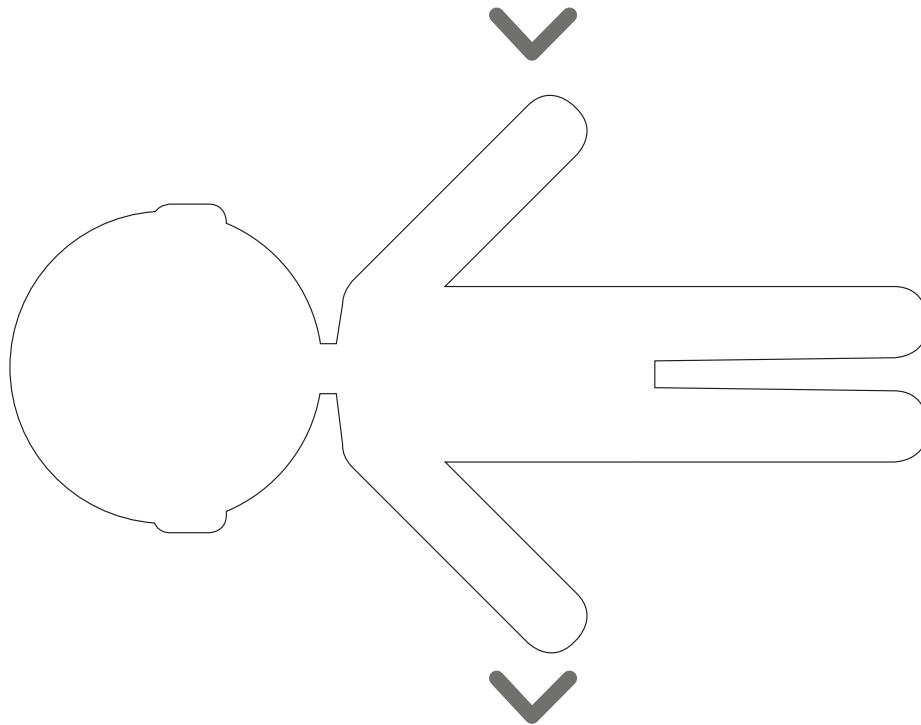



Repasa con el dedo y luego con tu lápiz el camino que debe seguir el conejo para encontrar las zanahorias.





Representar gráficamente distintos trazos

Repasa con el dedo y luego con tu lápiz el camino que deben seguir los niños para llegar al colegio.

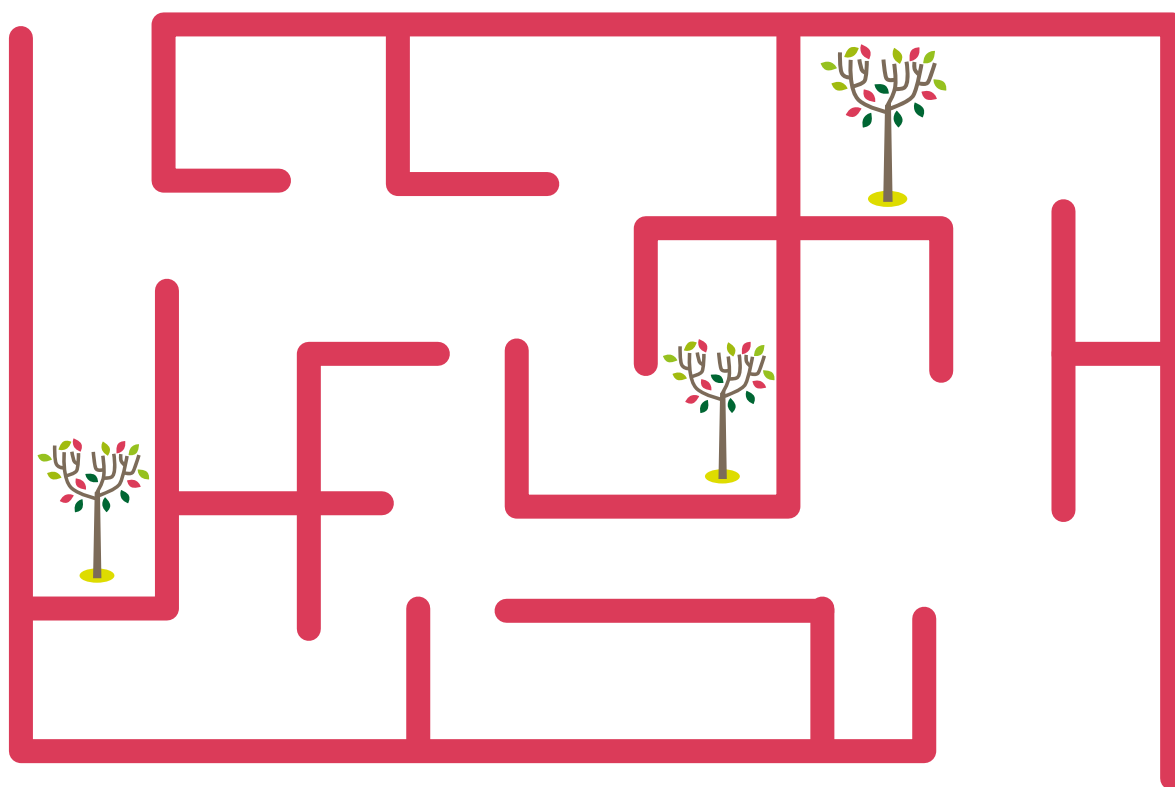



Recorta las imágenes del anexo a continuación. Pégalos formando las parejas que riman.

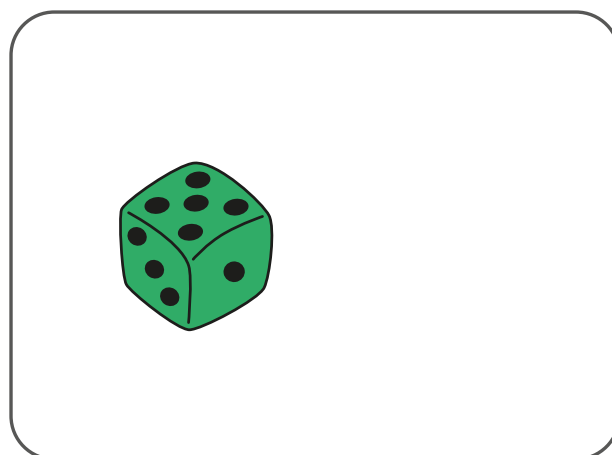
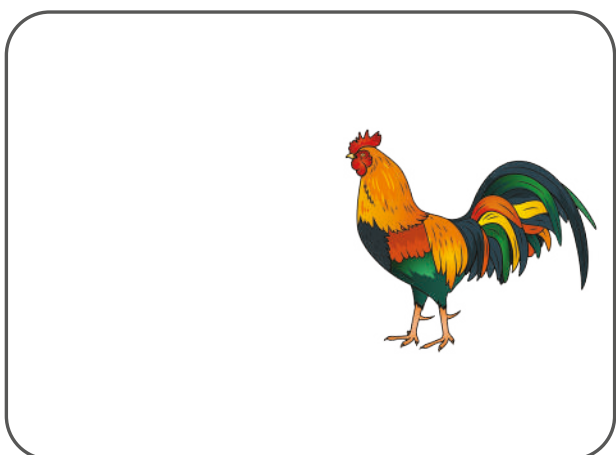
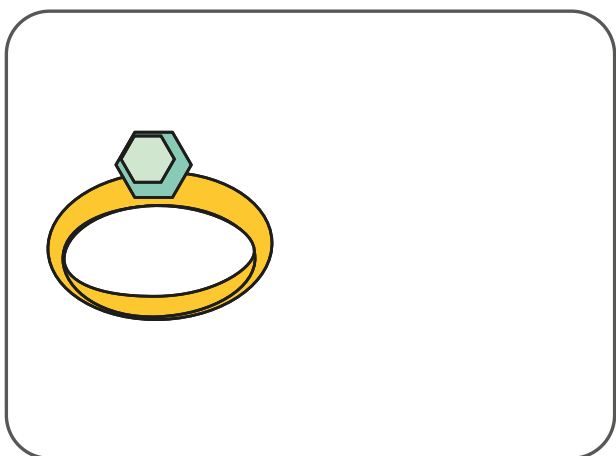
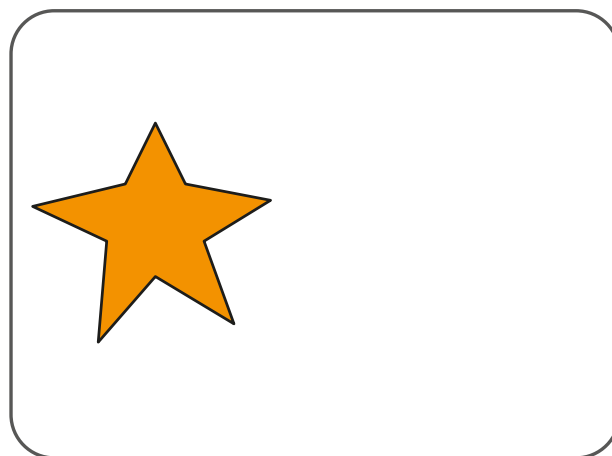
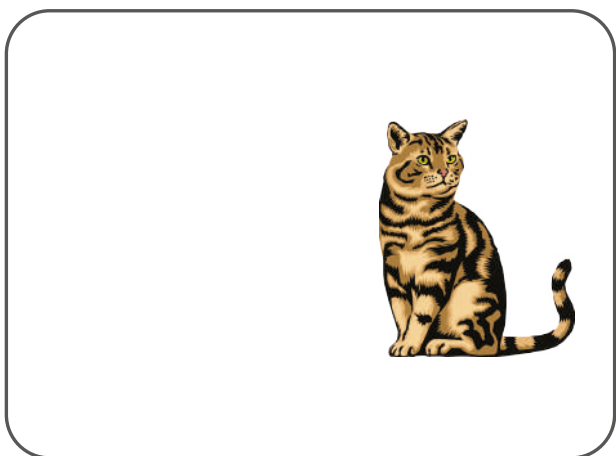



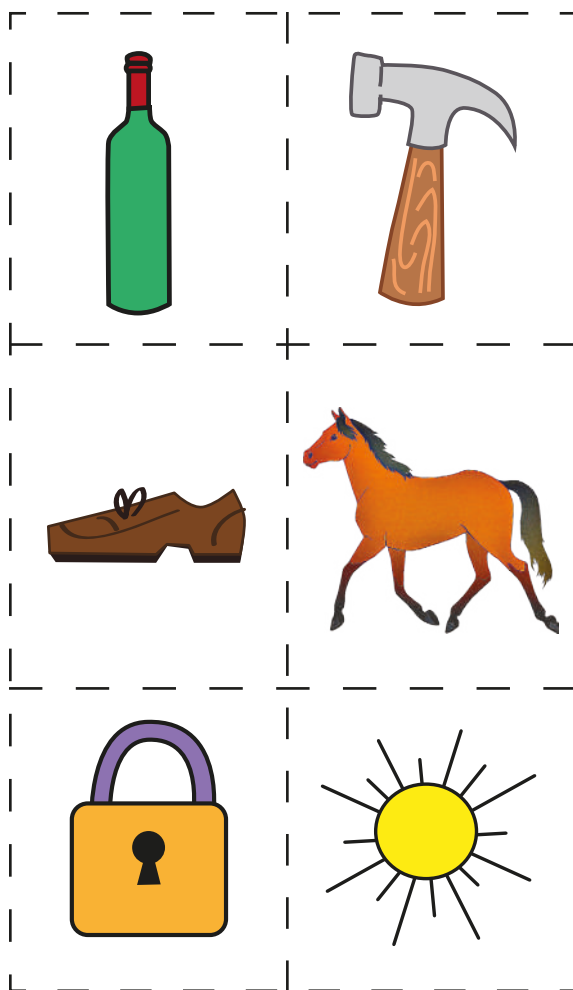



Ordenar elementos según su altura

13
actividad

Recorta los árboles del anexo a continuación. Ordénalos y pégalos según su altura.

--	--	--	--



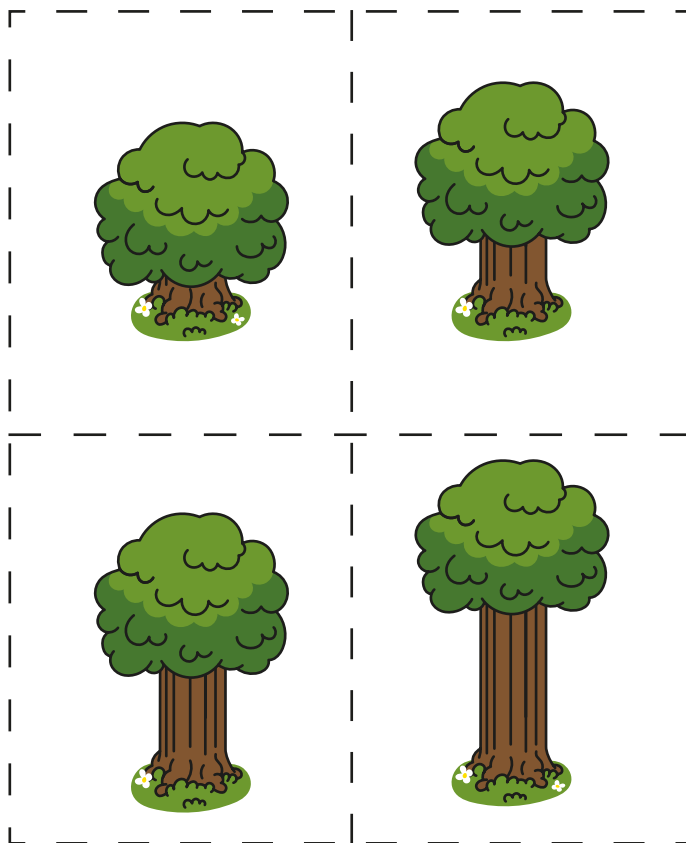



Ordenar elementos según alguna propiedad

14
actividad

Crea una serie de 4 elementos con el material de las colecciones. Dibuja la serie en los recuadros.

--	--	--	--

Criterio utilizado: _____



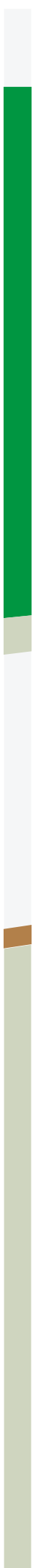

UNIDAD 3

EMOCIONES Y SENTIMIENTOS



PRIMERO
LEE



Repasa con tu dedo y luego con tu lápiz el camino que debe seguir cada ratón para llegar a su queso.

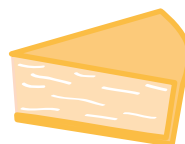
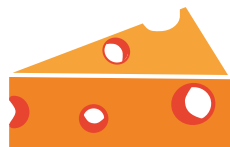
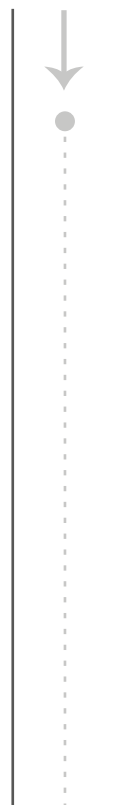
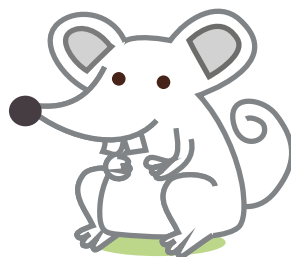
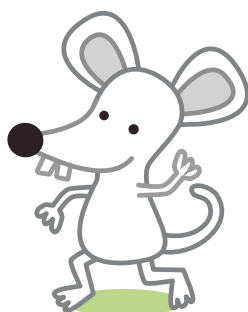



Repasa con tu dedo y luego con tu lápiz el camino que debe seguir cada animal para llegar a su casa.

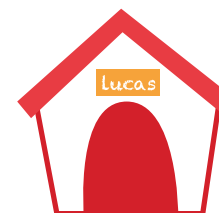
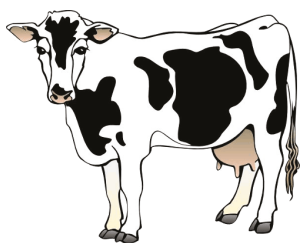



Repasa con tu dedo y luego con tu lápiz el camino que deja el caracol.

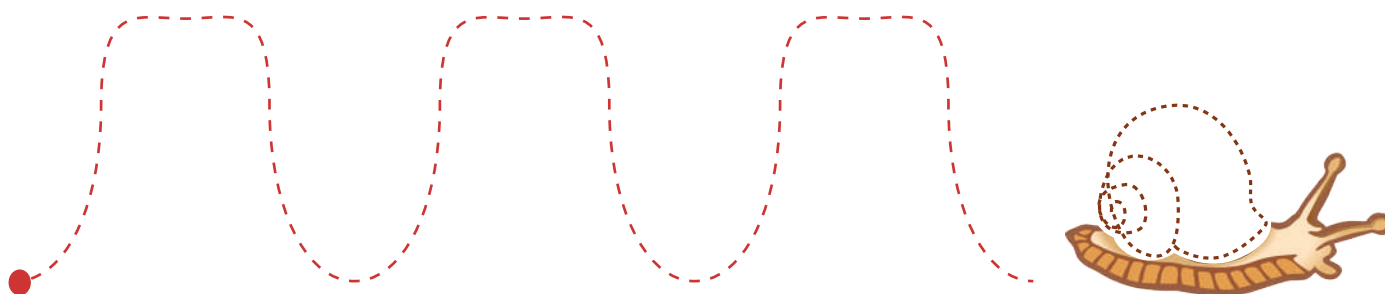
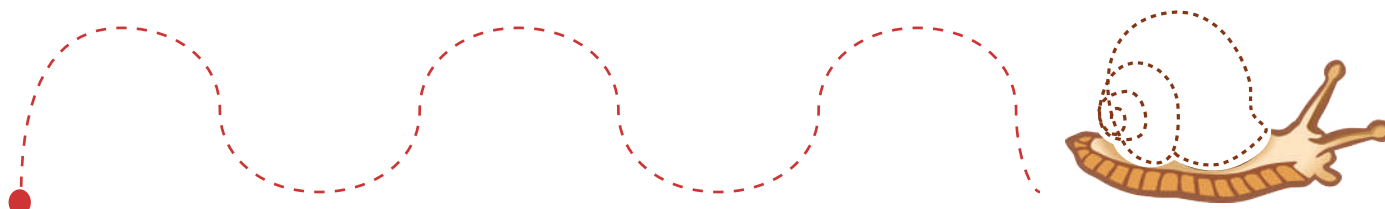
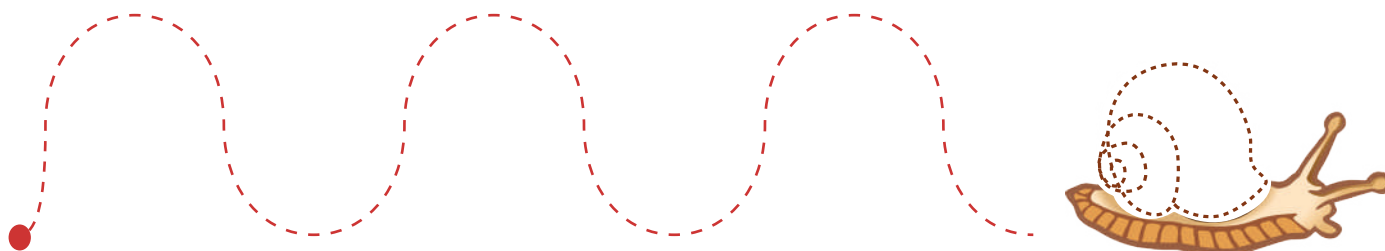



Repasa con tu dedo y luego con tu lápiz el camino que dejan las abejas.

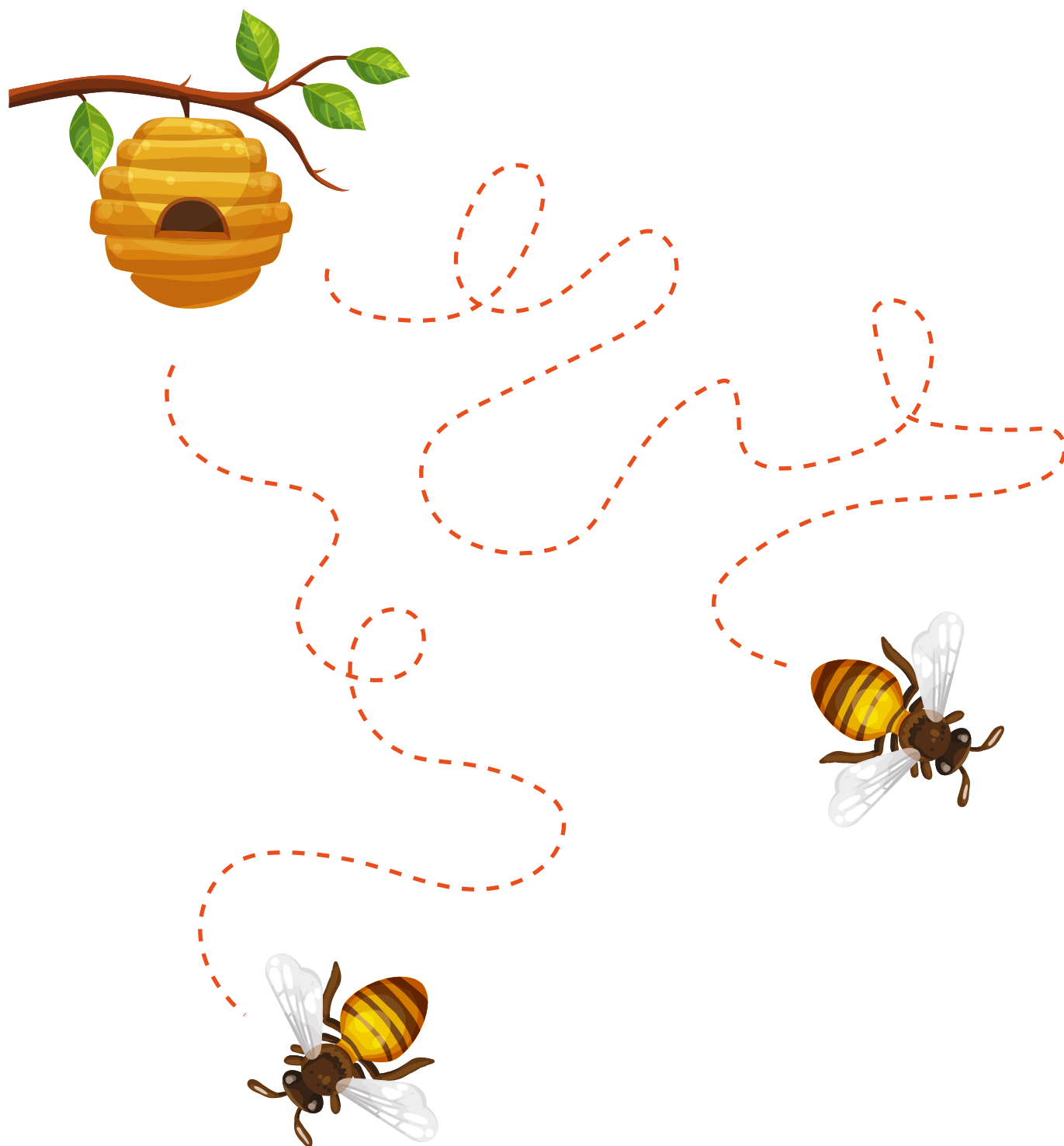



Reconocer cantidad de sílabas en una palabra

Pinta tantos recuadros como sílabas tenga la palabra.



□ □ □ □ □



□ □ □ □ □



□ □ □ □ □



□ □ □ □ □



□ □ □ □ □





Clasificar elementos considerando 2 criterios a la vez

20
actividad

Recorta las figuras del anexo a continuación. Selecciona algunas de ellas y clasifícalas considerando dos de sus características. Pégalas.











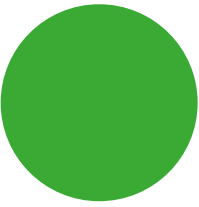

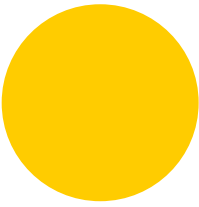





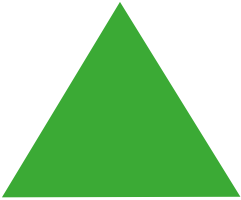

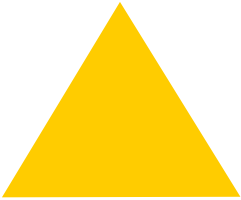
Criterios o características utilizados: _____

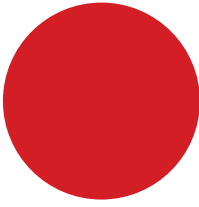

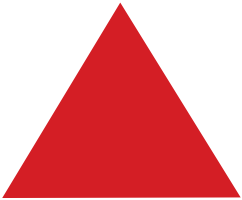





Pinta del mismo color los dibujos que tienen igual cantidad de sílabas.



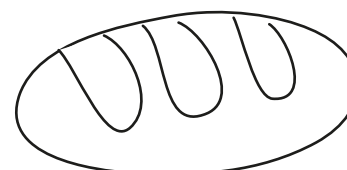
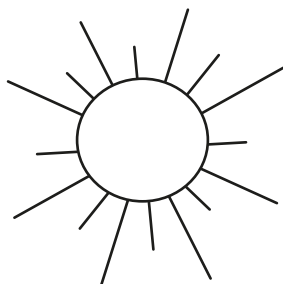
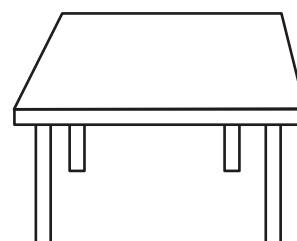
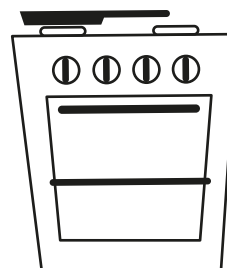
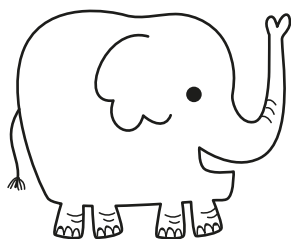
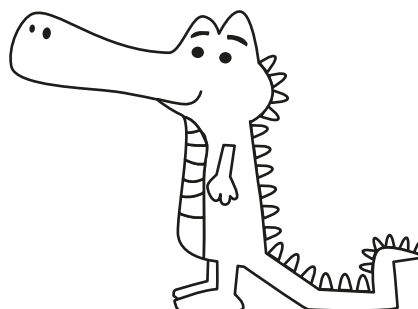

Identificar nociones espaciales de ubicación: dentro, fuera

Pinta de color amarillo los juguetes que están dentro de la caja.
Pinta de color verde los juguetes que están ubicados fuera de la caja.





Repasa con tu dedo y luego con tu lápiz los dibujos de este cuadro.
¡Píntalos como más te guste!

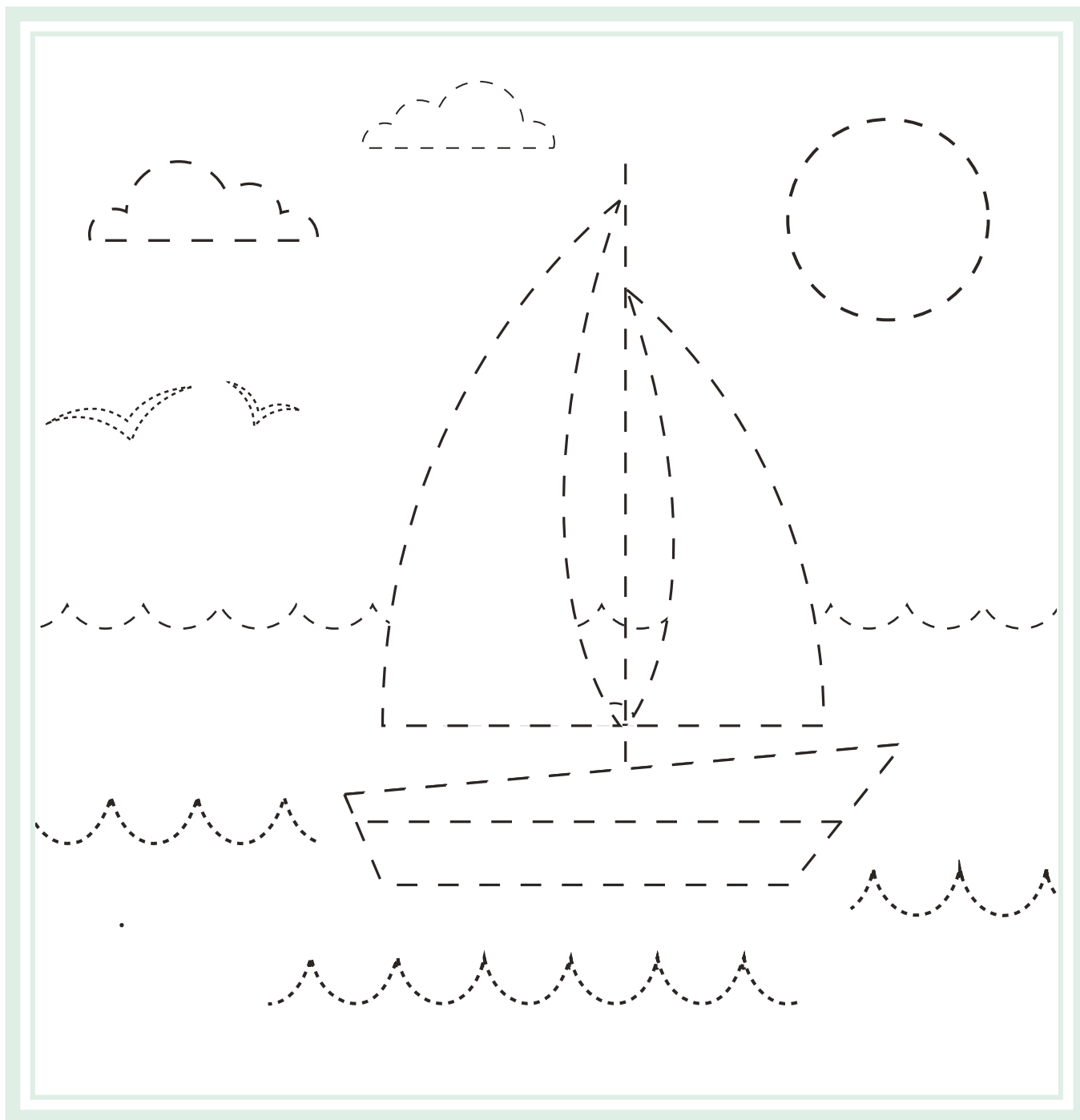



Reconocer la cantidad de sílabas en una palabra

Dibuja un círculo por cada sílaba que tenga el nombre de cada elemento.













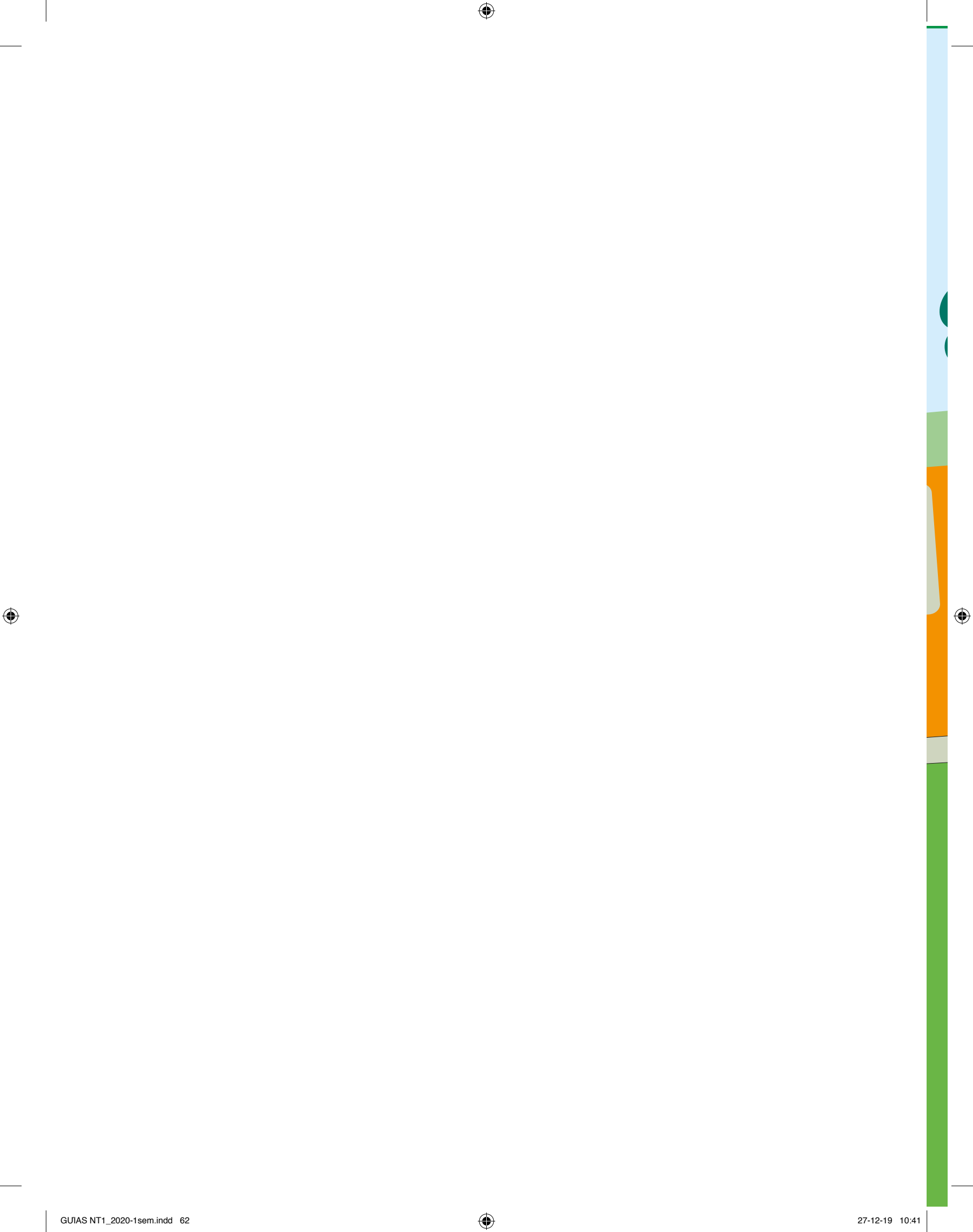

UNIDAD 4

ANIMALES



PRIMERO
LEE



Identificar patrones simples

25 actividad

En cada riel, pinta  si las acciones representan un patrón o pinta  si las acciones no representan un patrón.

Row 1: A sequence of 10 illustrations in a rounded rectangle. The first 5 are a boy sitting on a green chair, and the next 5 are a boy standing. To the right are two boxes: the first contains a checkmark, and the second contains an 'X'.

Row 2: A sequence of 10 circular illustrations. The first 5 show a girl with red pigtails in a purple top, and the next 5 show a girl with red pigtails in a pink top. To the right are two boxes: the first contains a checkmark, and the second contains an 'X'.

Row 3: A sequence of 10 illustrations in a rounded rectangle. The first 5 are a boy sitting on a green chair, and the next 5 are a girl with red pigtails in a purple top. To the right are two boxes: the first contains a checkmark, and the second contains an 'X'.

Row 4: A sequence of 10 illustrations in a rounded rectangle. The first 9 are circular illustrations: 5 of a girl with red pigtails in a pink top, 3 of a boy sitting on a green chair, and 1 of a girl with red pigtails in a purple top. The 10th illustration is a girl with red pigtails in a pink top jumping rope. To the right are two boxes: the first contains a checkmark, and the second contains an 'X'.



Pinta los objetos que comiencen con el mismo sonido que araña, completando el camino hasta la letra A.

A grid of 17 boxes arranged in four rows. The first row has one box with a spider. The second row has four boxes: a tree, a bee, a butterfly, and a lion. The third row has four boxes: a chair, a ring, a pencil, and a watermelon slice. The fourth row has four boxes: a beach ball, a car, an airplane, and a bed. Below the grid is a single box containing the letter 'A'.



Escribe el sonido inicial de cada dibujo.















Pinta los objetos que comiencen con el mismo sonido que oso, completando el camino hasta la letra O.

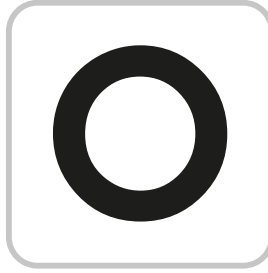
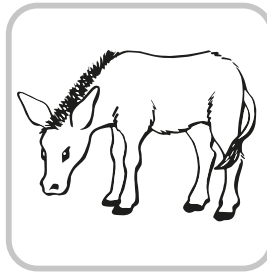
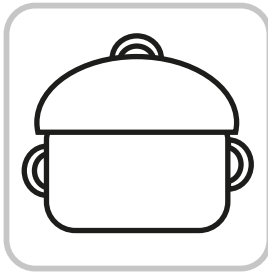
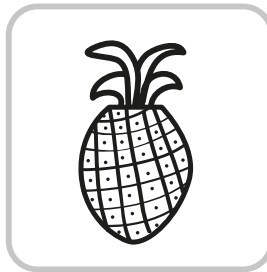
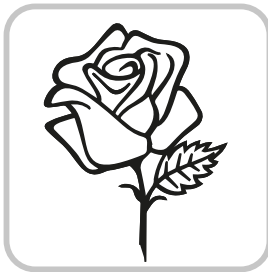
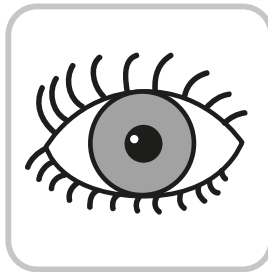
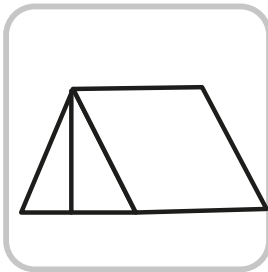
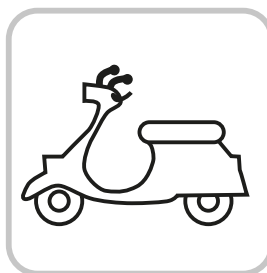
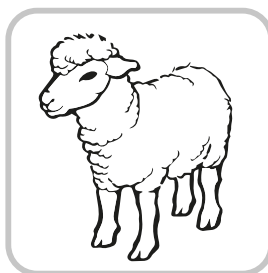





Three horizontal lines for writing, contained within a rounded rectangular box.



Extender patrones simples AB

30 actividad

Pinta extendiendo cada patrón:

The activity consists of four vertical strips, each containing a sequence of colored circles followed by seven empty circles for coloring. The patterns are as follows:

- Strip 1: Green, Purple, Green, Purple, 7 empty circles.
- Strip 2: Red, Yellow, Red, Yellow, 7 empty circles.
- Strip 3: Orange, Light Blue, Orange, Light Blue, 7 empty circles.
- Strip 4: Purple, Green, Purple, Green, 7 empty circles.



Pinta los objetos que comiencen con el mismo sonido que elefante, completando el camino hasta la letra E.

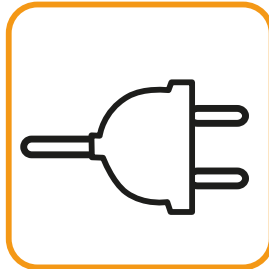
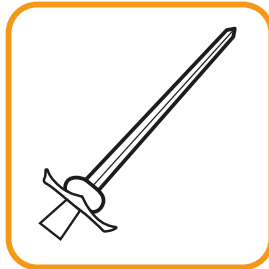
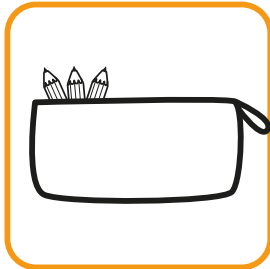
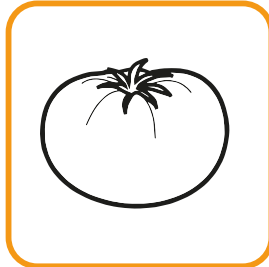
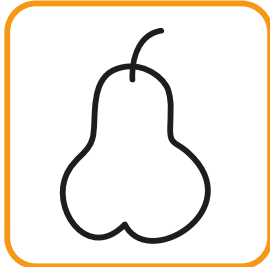
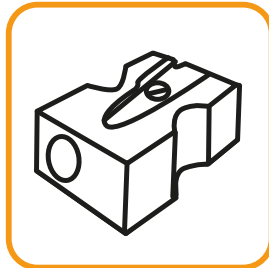
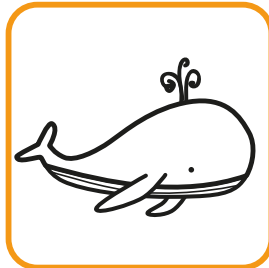
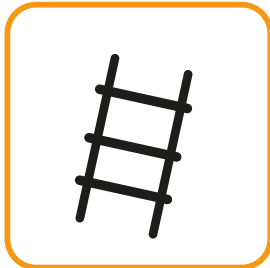



Reconocer elemento que no pertenece al patrón

En cada recuadro, encierra el o los elementos que no pertenecen al patrón.

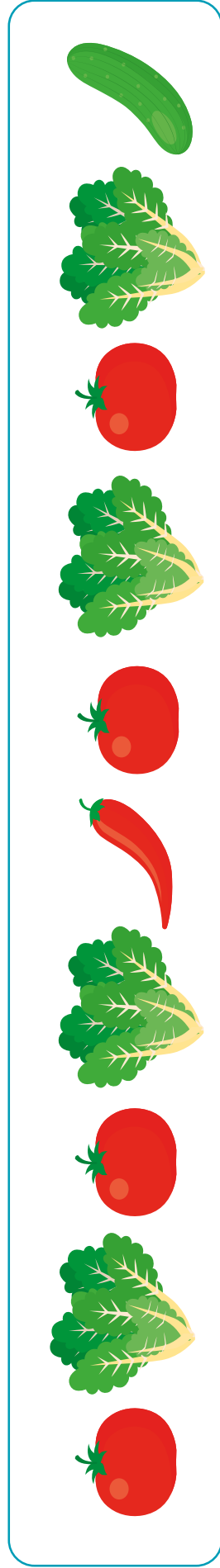
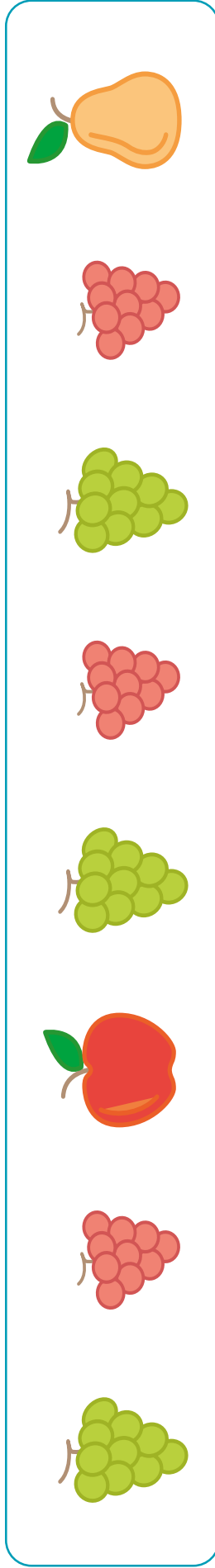
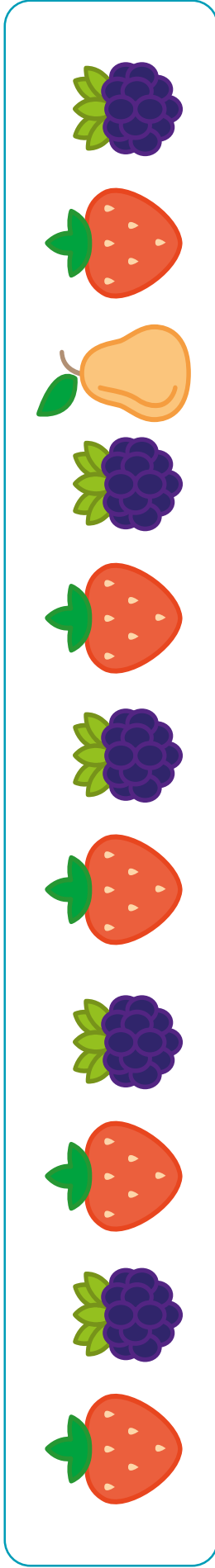
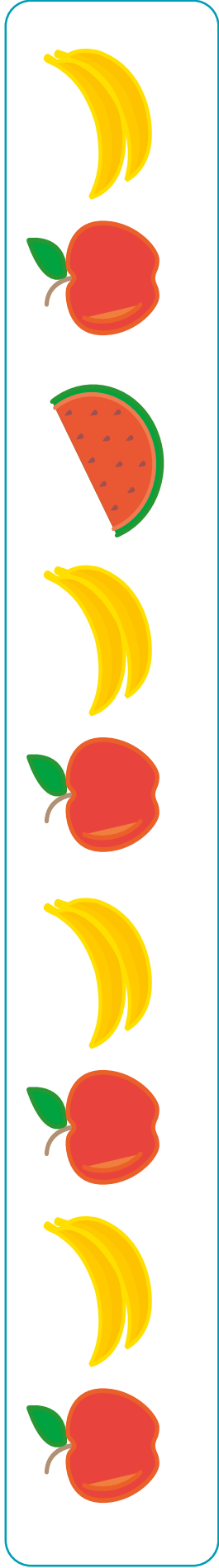



Inventa y escribe un nombre para cada uno de estos animales.









Pinta los objetos que comiencen con el mismo sonido que iguana, completando el camino hasta la letra i.

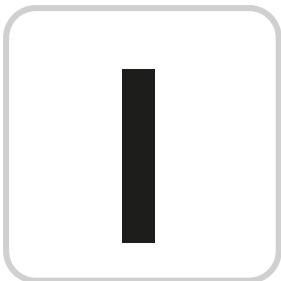
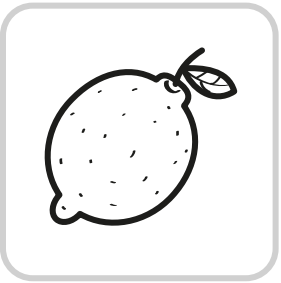
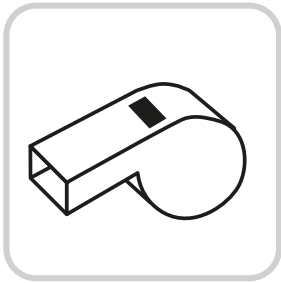
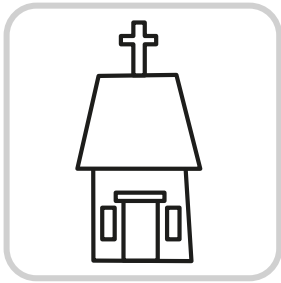
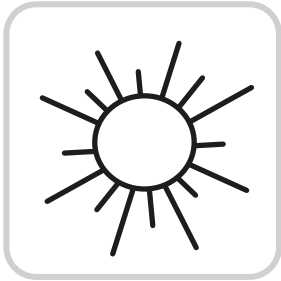
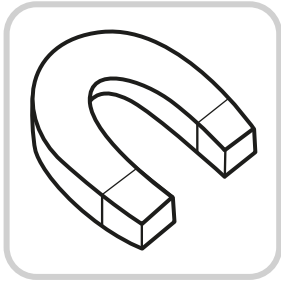



Crear patrones simples

35
actividad

Crea un patrón y luego dibújalo.



CONSEJO 1

36
actividad



Mis consejos para un día de campo

Nombre _____

CONSEJO 2

CONSEJO 3





Pinta los objetos que comiencen con el mismo sonido que unicornio, completando el camino hasta la letra U.

